

VCS 16080 R 38(3) AC MB

Features

- Galvanized steel electro coated black housing
- Plastic wheel
- Single inlet
- 3-phase, 2-pole motor
- operating temp.: -20~+70 °C
- IP class: IP 44
- Electrical insulation class: F
- Weight: 5 kg



Model	Voltage VAC	Frequency Hz	Current A	Input Power (W)	Speed RPM	Airflow (m ³ /h)	Static pressure (Pa)	Sound level dBA
VCD 16080 R 38(3) AC MB	380 (3 phase)	50	0.6	330	2700	660	480	76

*: above specifications are subject to change without prior notice

**: for non-standard product, contact our sale's team at sales@ventus-sa.com

Dimensions

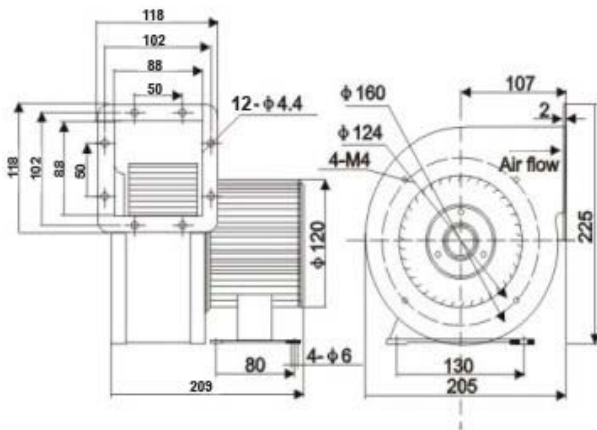

Performance

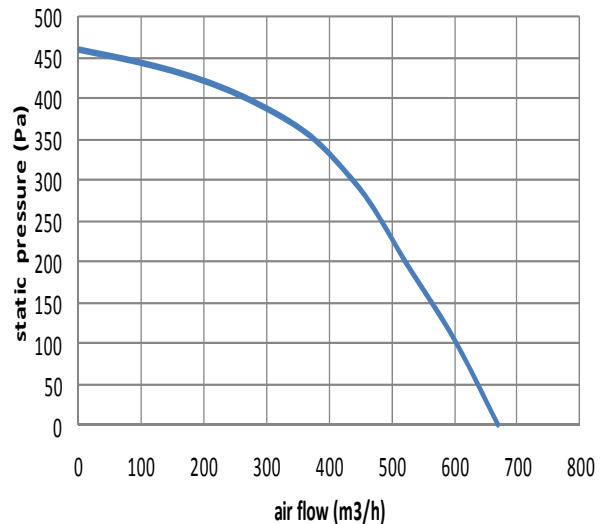

Ordering Code:

Fan type	Single Inlet	Wheel Dimensions	Motor position	Voltage	motor		-	Other specs*
			Right when facing outlet	380VAC, 3 phase	2-pole	4-pole		
VC	S	16080	R	38(3) AC	MB	-	-	/O

*: if the ordered item is not standard fans offered on our website, always put "/O" at the end of the ordering code and specify the project number which is unique for any non-standard products. Sales team will provide this project number together with specs sheet confirmed by both parties.

Example: VCS 16080 R 38(3) AC MB