

VCD 133180 ED 16 series

Features

- Galvanized steel housing
- Galvanized steel wheel
- Double inlet
- DC input EC motor
- operating temp.: -25~+60 °C
- PWM speed control (0-10VDC, 1~10kHz)
- Tachometer output signal
- Polarity and locked rotor protection
- IP class: IP 44
- Electrical insulation class: B
- Weight: 3.5 kg



Model	Voltage VDC	Current A	Input Power W	Speed RPM	Airflow m ³ /h	Static pressure mmH ₂ O	Sound level dBA
VCD 133180 24 ED 16	24	6.0	118	1580	1020	44	64
VCD 133180 48 ED 16	48	3.0	118	1580	1020	44	64

*: above specifications are subject to change without prior notice

**: for non-standard product, contact our sale's team at sales@ventus-sa.com

Dimensions

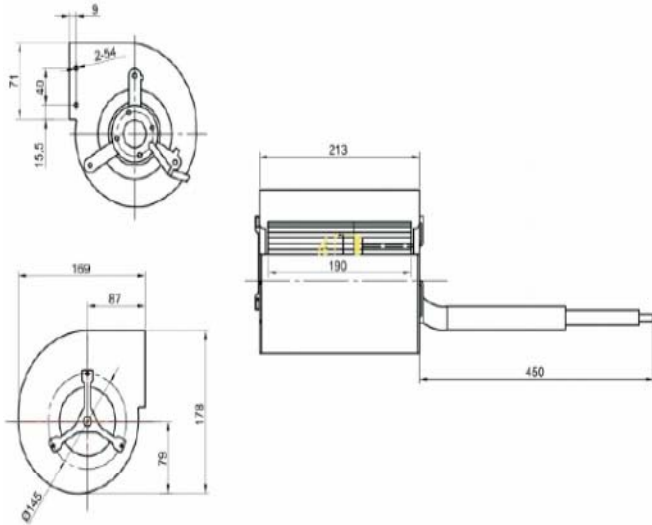

Performance

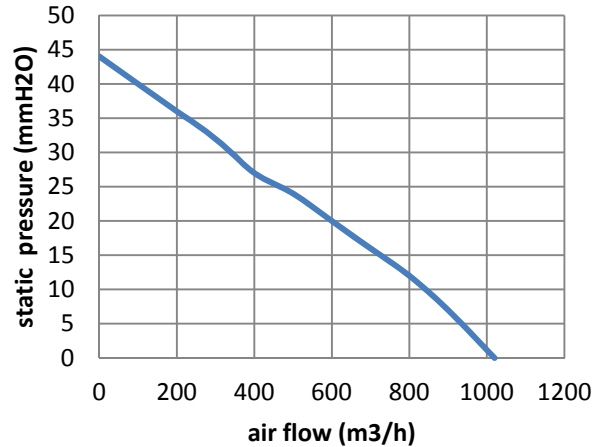

Ordering Code:

Fan type	Single Inlet	Wheel Dimensions	Voltage (VDC)		motor	Speed	-	Other specs*
			24	48				
VC	D	133180	24	48	ED	16	-	/O

*: if the ordered item is not standard fans offered on our website, always put "/O" at the end of the ordering code and specify the project number which is unique for any non-standard products. Sales team will provide this project number together with specs sheet confirmed by both parties.

Example: VCD 133180 24 ED 16