

## VC14580ACERT02

### Dimensions

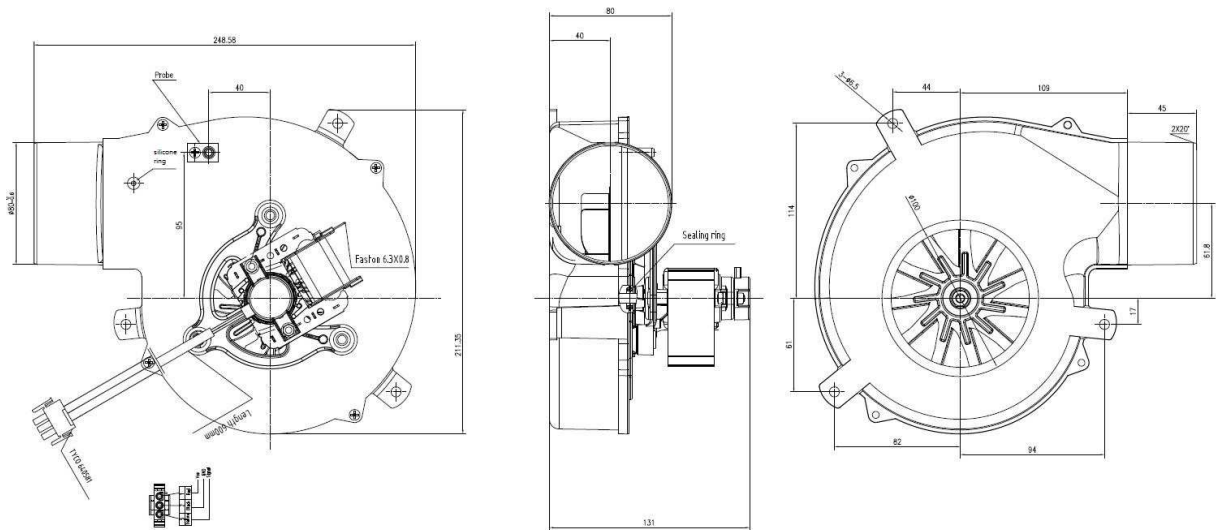

### Features

- power supply: 230 VAC
- frequency: 50 Hz
- input power: 50 W
- speed: 2500 RPM
- max. air flow: 145 m<sup>3</sup>/h
- max. static pressure: 280 Pa
- wheel material: stainless steel
- housing material: aluminum
- rotation: CCW from wheel
- shaded-pole with two ball bearings
- insulation class: H

with tachometer

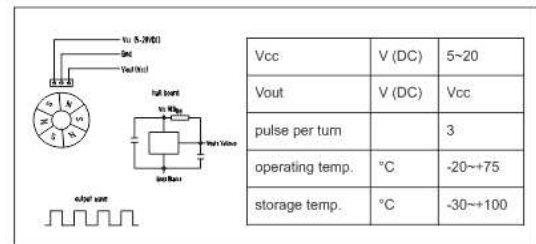

\*: above specifications are subject to change without prior notice

\*\* : for non-standard product, contact our sale's team at [sales@ventus-sa.com](mailto:sales@ventus-sa.com)