

## FC 1738 W B 28 M

- global voltage
- low power consumption
- magnesium alloy die-casting frame
- magnesium alloy die-casting impeller
- electrical connections: terminals
- double ball bearing
- operating temp.: -10~+70 °C
- life time: 60000 hrs (40 °C, 65%RH)
- unit weight ~700 g



model	voltage VAC	start voltage VAC	power W	speed rpm	air flow cfm	sound level dBA
FA 1738 W B 28M	90~264	63	10	2800	180	57

\*: Contact Ventus sales team for the product availability with different air flow.

\*\* : specifications listed above are subject to change without prior notice.

### dimensions

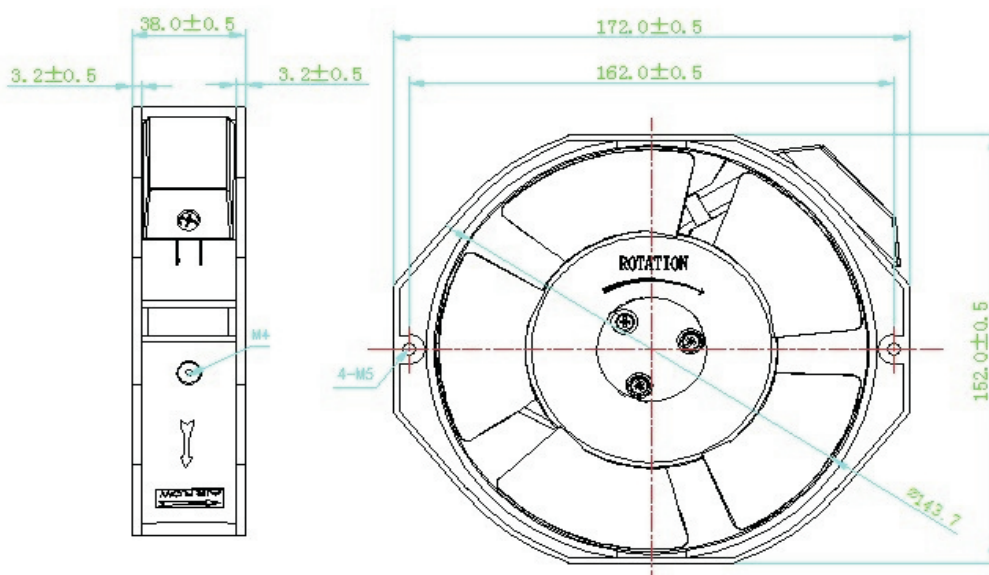

\*\*\*: the real product might differ from what shown in the photo. Referring to the drawings for accurate dimensions.