

FA 1865 26 series (180x180x65 mm)

Features

- Die cast Aluminum alloy frame
- UL94V-0 plastic impeller
- Ball bearing
- Electrical connections: terminals or lead wires
- Operating temp.: -10~+65 °C
- Life time: 60000 hrs@20 °C
- Capacitor-run induction motor
- Weight: 1200 g
- Certificates: CE



Model	Voltage VAC	Frequency Hz	Current A	Input Power W	Speed RPM	Airflow cfm	Static pressure mmH ₂ O	Capacitor (μF/250V)	Sound level dBA
FA 1865 11 B 26	110/120	50/60	0.42	45	2600/3000	345/395	25/33	3.3	63/68
FA 1865 23 B 26	220/240	50/60	0.22	45	2600/3000	345/395	25/33	1.5	63/68

*: above specifications are subject to change without prior notice

**: for non-standard product, contact our sale's team at info@ventus-sa.com

Dimensions

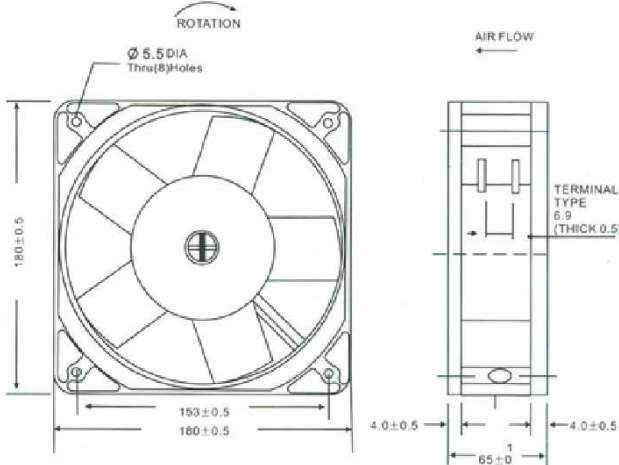

Performance

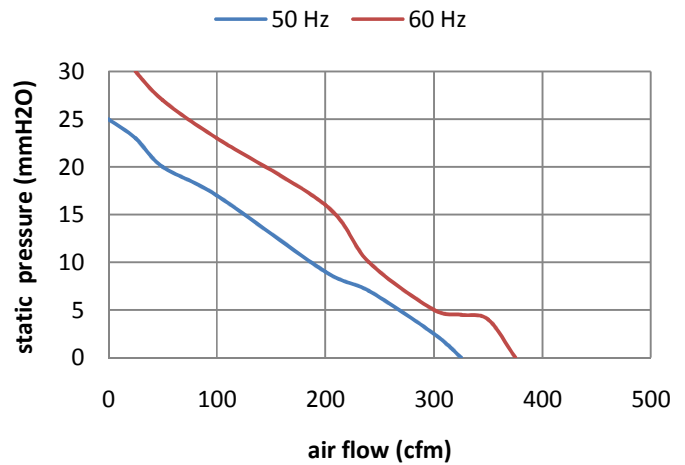

Ordering Code:

Fan type	Dimensions	Voltage (VAC)		Bearing type		Speed	-	Electrical connections		Other specs*
		110	230	Ball	sleeve			Terminals	Lead wires	
FA	1865	11	23	B	-	26	-	C	L	/O

*: if the ordered item is not standard fans offered on our website, always put "/O" at the end of the ordering code and specify the project number which is unique for any non-standard products. Sales team will provide this project number together with specs sheet confirmed by both parties.

Example: FA 1865 23 B 26 -C