

FA 1751 27M series

(172x150x51 mm)

Features

- Die cast magnesium frame
- Die cast magnesium impeller
- Sleeve or ball bearing
- Electrical connections: Terminals or lead wires
- Operating temp.: -20~+80 °C
- Life time: 50000 hrs@20 °C (ball bearing)
- Impedance protection
- IP class: IP 55
- Weight: 850 g
- Certificates: CE



Model	Voltage VAC	Frequency Hz	Current A	Input Power (W)	Speed RPM	Airflow CFM	Static pressure (InH2O)	Sound level dBA
FA 1751 11 # 27M	110/120	50/60	0.40/0.35	31/28	2700/3100	180/210	0.48/0.58	56/58
FA 1751 23 # 27M	220/240	50/60	0.20/0.17	30/28	2700/3100	180/210	0.48/0.58	56/58
FA 1751 38 # 27M	380/400	50/60	0.13/0.11	32/29	2700/3100	180/210	0.48/0.58	56/58

*: above specifications are subject to change without prior notice

**: for non-standard product, contact our sale's team at info@ventus-sa.com

Dimensions

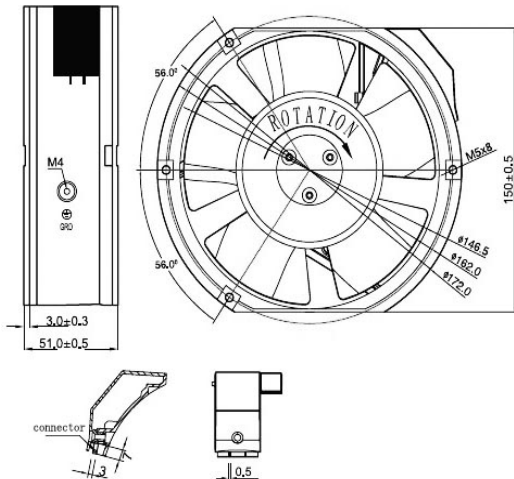

Performance

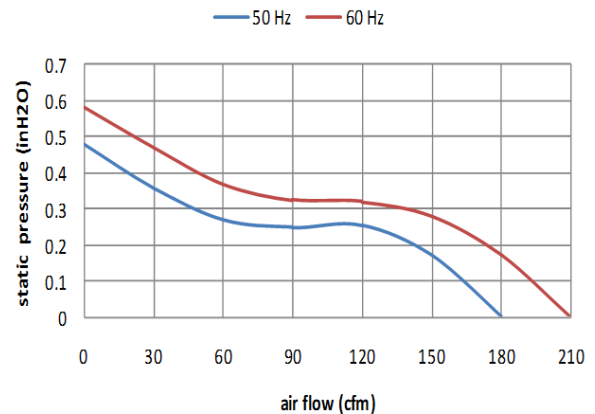

Ordering Code:

Fan type	Dimensions	Voltage			Bearing type		Speed	Optional	Electrical connections		Other specs*	
		110	230	380	Ball	sleeve			Metal impeller	-		Terminals
FA	1751	11	23	38	B	S	27	M	-	C	L	/O

*: if the ordered item is not standard fans offered on our website, always put "/O" at the end of the ordering code and specify the project number which is unique for any non-standard products. Sales team will provide this project number together with specs sheet confirmed by both parties.

Example: FA 1751 23 B 27M-C